



KERN is a broad system of modular seating elements designed for gathering and waiting. A fully modular family of elements that can be used independently or be freely combined to create functional and unique compositions suitable for any interaction or waiting space. KERN modules can be easily rearranged to create modern and flexible spaces to wait, meet, work or simply relax.

Its full modular spirit and the wide variety of modules available, make it a truly adaptable and transversal system suitable for every interaction space or context.

KERN is composed by four collections: sofas, modular seats, meeting booths and occasional tables. The combination of these four collections creates a complete universe of versatile elements able to solve the needs of today's interaction and waiting spaces.

FINISHES

Leg finishes

M1 colours



M2 colours

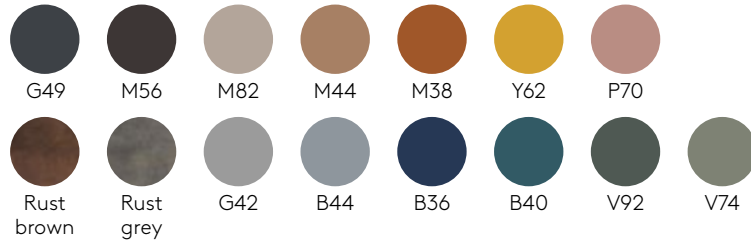

Upholstery: Available in all fabrics and leathers indicated in our finishes book.

Tabletops

Lacquered MDF
22mm

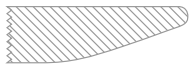

W1 colours



W2 colours

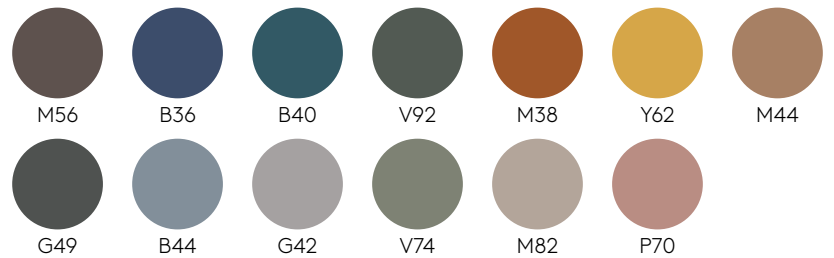

Oak & walnut veneer
23mm

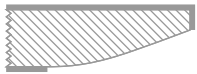

Oak



Walnut



Solid FENIX®
12mm black core

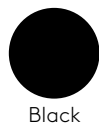

Solid HPL
12mm white core



Solid HPL
12mm sand core

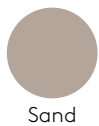

Solid HPL STONES
12mm

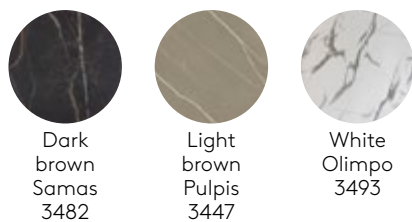

Finishes book [+info](#)

TECHNICAL INFORMATION

Product data sheet [+info](#)

ENVIRONMENT & HEALTH

INCLASS production processes are certified according to environmental standards ISO 14001 in order to minimise any impact on the environment. ISO 14001 certificate [+info](#)

FIRE REQUIREMENTS

The polyurethane foam of the backrest meets BS 5852, ignition source 0 and 1, and CAL 117. The polyurethane foam of the seat meets BS 5852 CRIB 5 and CAL 117.

*We recommend the use of wool or non-flammable synthetic fabrics.

*Please contact our Customer Service department if your project has specific flammability needs or if you need to know if all components comply with the required standards.

QUALITY STANDARDS

The quality management system of INCLASS is certified in accordance with ISO 9001 in all the design, manufacturing and sales procedures of its products.
ISO 9001 certificate [+info](#)

PRODUCT CERTIFICATIONS

UNE-EN 16139:2013vc2015 - Furniture - Strength, durability and safety - Requirements for non-domestic seating.

ANSI/BIFMA X5.4:2020 - Public and Lounge Seating.

*INCLASS products have been extensively tested to exceed industry testing standards at AIDIMME.
AIDIMME is member of the European network INNOVAWOOD and its testing laboratories are accredited by ENAC.*

COMPANY CERTIFICATIONS & ACCREDITATIONS

ISO 9001 - Quality management systems

ISO 14001 - Environmental management systems

FSC® - The mark of responsible forestry. Certificate C194846

AIDIMME Partner - Metal-processing, furniture, wood and packaging technology institute

IBV Partner - Valencia Institute of Biomechanics

ADVC Membership - Association of Designers of the Valencian Community

ENVALORA Membership - Collective System of Extended Producer Responsibility

WARRANTY

5 years

ARMCHAIRS & SOFAS

Armchair with swivel base

Code: **KER0010**



Upholstered swivel armchair. Inner seat made of plywood padded with CMHR polyurethane foam of various densities covered with soft polyester fiber. Backrest with inner frame in steel padded with CMHR polyurethane foam of 50kg/m³ covered with soft polyester fiber. Optionally the armchair can incorporate an upholstered privacy screen made of plywood and polyester fibre.

Upholstery: in all the fabrics and leathers indicated in our finishes book.

Base finishes: polished or micro-textured powder coated in black or white.

Glides: plastic glides as standard. Felt glides are available with an upcharge.

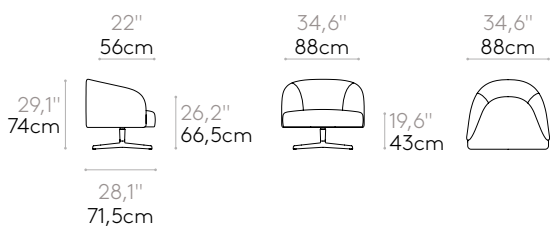

COM 140cm / 55,1" per unit	
1 unit	286cm / 112,6"
8 or more units	283cm / 111,4"
COM will be priced as G2	

KG	27,5kg	1 unit	33 kg
			0,61 m ³
			0,80 yd ³

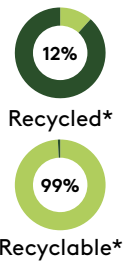

Armchair with 4 legs

Code: **KER0020**



Upholstered lounge armchair. Inner seat made of plywood padded with CMHR polyurethane foam of various densities covered with soft polyester fiber. Backrest with inner frame in steel padded with CMHR polyurethane foam of 50kg/m³ covered with soft polyester fiber. Optionally the armchair can incorporate an upholstered privacy screen made of plywood and polyester fibre.

Upholstery: in all the fabrics and leathers indicated in our finishes book.

Legs: cast aluminum legs painted in all the M1 and M2 colours of our metal swatch card. Optionally available with polished finish.

Glides: plastic glides as standard. Felt glides are available with an upcharge.

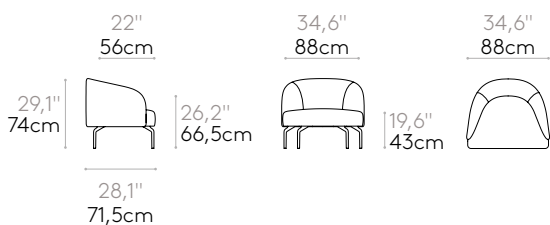

COM 140cm / 55,1" per unit	
1 unit	286cm / 112,6"
8 or more units	283cm / 111,4"
COM will be priced as G2	

KG	24,9kg	1 unit	27,6 kg
			0,50 m ³
			0,66 yd ³

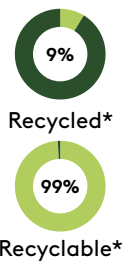

* Numbers may vary based on the exact options selected.

Two seater sofa

Code: **KER0030**



Upholstered two seater sofa. Inner seat made of plywood padded with CMHR polyurethane foam of various densities covered with soft polyester fiber. Backrest with inner frame in steel padded with CMHR polyurethane foam of 50kg/m³ covered with soft polyester fiber. Optionally the sofa can incorporate an upholstered privacy screen made of plywood and polyester fibre.

Upholstery: in all the fabrics and leathers indicated in our finishes book.

Legs: cast aluminum legs painted in all the M1 and M2 colours of our metal swatch card. Optionally available with polished finish.

Glides: plastic glides as standard. Felt glides are available with an upcharge.

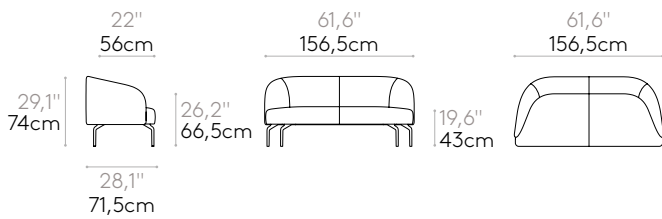

COM 140cm / 55,1" per unit	
1 unit	441,5cm / 173,8"
8 or more units	436cm / 171,7"
COM will be priced as G2	

KG	28,9kg	KD	1 unit	37,4 kg
				0,88 m ³
				1,15 yd ³

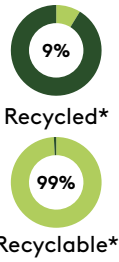

Three seater sofa

Code: **KER0040**



Upholstered three seater sofa. Inner seat made of plywood padded with CMHR polyurethane foam of various densities covered with soft polyester fiber. Backrest with inner frame in steel padded with CMHR polyurethane foam of 50kg/m³ covered with soft polyester fiber. Optionally the sofa can incorporate an upholstered privacy screen made of plywood and polyester fibre.

Upholstery: in all the fabrics and leathers indicated in our finishes book.

Legs: cast aluminum legs painted in all the M1 and M2 colours of our metal swatch card. Optionally available with polished finish.

Glides: plastic glides as standard. Felt glides are available with an upcharge.

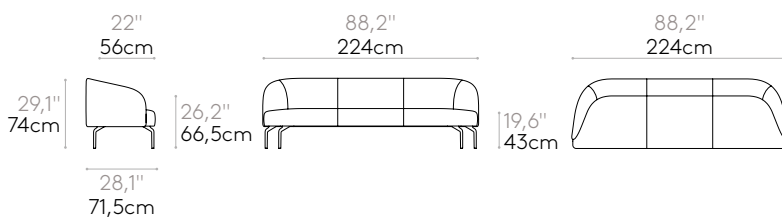

COM 140cm / 55,1" per unit	
1 unit	453,5cm / 178,5"
8 or more units	437cm / 172"
COM will be priced as G2	

KG	52,1kg	KD	1 unit	71,3 kg
				1,21 m ³
				1,58 yd ³

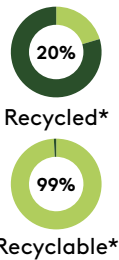

* Numbers may vary based on the exact options selected.

MODULES

One seater module

Code: **KER0110**



Upholstered seat module. Inner seat made of plywood padded with CMHR polyurethane foam of various densities covered with soft polyester fiber.

Upholstery: in all the fabrics and leathers indicated in our finishes book.

Legs: cast aluminum legs painted in all the M1 and M2 colours of our metal swatch card. Optionally available with polished finish.

Glides: plastic glides as standard. Felt glides are available with an upcharge.



COM 140cm / 55,1" per unit

1 unit	157,5cm / 62"
8 or more units	131cm / 51,6"

COM will be priced as G2

11,3kg

4 units
53,1 kg
0,78 m³
1,01 yd³
KD



Recycled*



Recyclable*

One seater module with backrest

Code: **KER0210**



Upholstered modular seat with backrest. Inner seat made of plywood padded with CMHR polyurethane foam of various densities covered with soft polyester fiber. Backrest with inner frame in steel padded with CMHR polyurethane foam of 50kg/m³ covered with soft polyester fiber. Optionally the module can incorporate an upholstered privacy screen made of plywood and polyester fibre.

Upholstery: in all the fabrics and leathers indicated in our finishes book.

Legs: cast aluminum legs painted in all the M1 and M2 colours of our metal swatch card. Optionally available with polished finish.

Glides: plastic glides as standard. Felt glides are available with an upcharge.

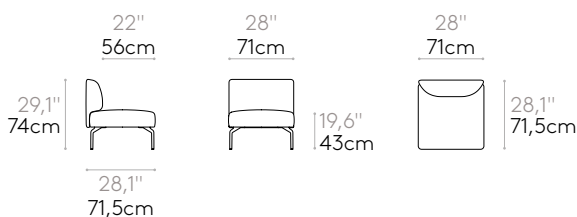

COM 140cm / 55,1" per unit

1 unit	233cm / 91,7"
8 or more units	212,5cm / 83,7"

COM will be priced as G2

15,6kg

2 units
39,1 kg
0,78 m³
1,01 yd³
KD



Recycled*



Recyclable*

* Numbers may vary based on the exact options selected.

One seater module with corner backrest

Code: **KER0212**



Upholstered modular seat with corner backrest. Inner seat made of plywood padded with CMHR polyurethane foam of various densities covered with soft polyester fiber. Backrest with inner frame in steel padded with CMHR polyurethane foam of 50kg/m³ covered with soft polyester fiber. Optionally the module can incorporate an upholstered privacy screen made of plywood and polyester fibre.

Upholstery: in all the fabrics and leathers indicated in our finishes book.

Legs: cast aluminum legs painted in all the M1 and M2 colours of our metal swatch card. Optionally available with polished finish.

Glides: plastic glides as standard. Felt glides are available with an upcharge.

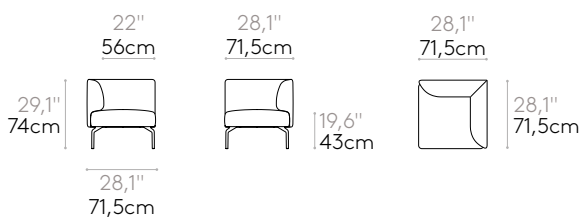

COM 140cm / 55,1" per unit	
1 unit	311,5cm / 122,6"
8 or more units	294cm / 115,7"
COM will be priced as G2	

23,8kg	2 units	55,3 kg 0,78 m ³ 1,01 yd ³
--------	---------	--

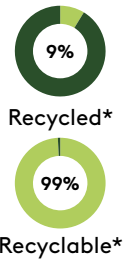

Two seater module

Code: **KER0120**



Upholstered two seater module. Inner seat made of plywood padded with CMHR polyurethane foam of various densities covered with soft polyester fiber.

Upholstery: in all the fabrics and leathers indicated in our finishes book.

Legs: cast aluminum legs painted in all the M1 and M2 colours of our metal swatch card. Optionally available with polished finish.

Glides: plastic glides as standard. Felt glides are available with an upcharge.

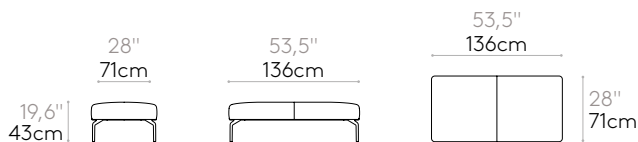

COM 140cm / 55,1" per unit	
1 unit	187cm / 73,6"
8 or more units	158,5cm / 62,4"
COM will be priced as G2	

18,4kg	2 units	46 kg 0,74 m ³ 0,97 yd ³
--------	---------	--

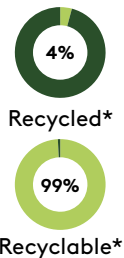

* Numbers may vary based on the exact options selected.

Two seater module with backrest

Code: **KER0220**



Upholstered two seater module with backrest. Inner seat made of plywood padded with CMHR polyurethane foam of various densities covered with soft polyester fiber. Backrest with inner frame in steel padded with CMHR polyurethane foam of 50kg/m³ covered with soft polyester fiber. Optionally the module can incorporate an upholstered privacy screen made of plywood and polyester fibre.

Upholstery: in all the fabrics and leathers indicated in our finishes book.

Legs: cast aluminum legs painted in all the M1 and M2 colours of our metal swatch card. Optionally available with polished finish.

Glides: plastic glides as standard. Felt glides are available with an upcharge.

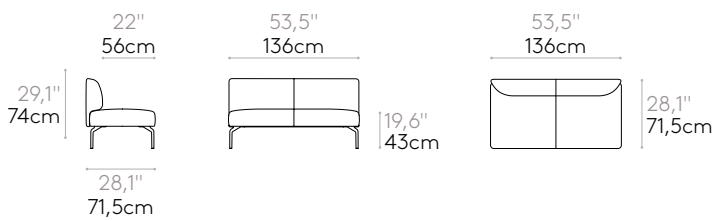

COM 140cm / 55,1" per unit	
1 unit	355,5cm / 140"
8 or more units	320,5cm / 126,2"
COM will be priced as G2	

28,5kg	1 unit	37 kg 0,74 m ³ 0,97 yd ³
--------	--------	--

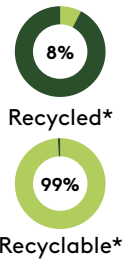

Two seater module with corner backrest (right)

Code: **KER0222**



Upholstered two seater module with right corner backrest. Inner seat made of plywood padded with CMHR polyurethane foam of various densities covered with soft polyester fiber. Backrest with inner frame in steel padded with CMHR polyurethane foam of 50kg/m³ covered with soft polyester fiber. Optionally the module can incorporate an upholstered privacy screen made of plywood and polyester fibre.

Upholstery: in all the fabrics and leathers indicated in our finishes book.

Legs: cast aluminum legs painted in all the M1 and M2 colours of our metal swatch card. Optionally available with polished finish.

Glides: plastic glides as standard. Felt glides are available with an upcharge.

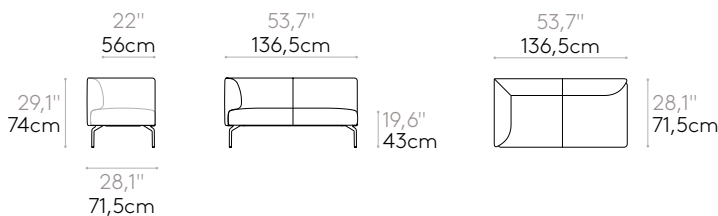

COM 140cm / 55,1" per unit	
1 unit	411,5cm / 162"
8 or more units	406cm / 159,8"
COM will be priced as G2	

37,1kg	1 unit	45,6 kg 0,75 m ³ 0,98 yd ³
--------	--------	--

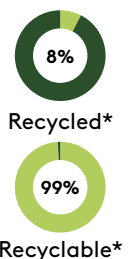

* Numbers may vary based on the exact options selected.

Two seater module with corner backrest (left)

Code: **KER0224**



Upholstered two seater module with left corner backrest. Inner seat made of plywood padded with CMHR polyurethane foam of various densities covered with soft polyester fiber. Backrest with inner frame in steel padded with CMHR polyurethane foam of 50kg/m³ covered with soft polyester fiber. Optionally the module can incorporate an upholstered privacy screen made of plywood and polyester fibre.

Upholstery: in all the fabrics and leathers indicated in our finishes book.

Legs: cast aluminum legs painted in all the M1 and M2 colours of our metal swatch card. Optionally available with polished finish.

Glides: plastic glides as standard. Felt glides are available with an upcharge.

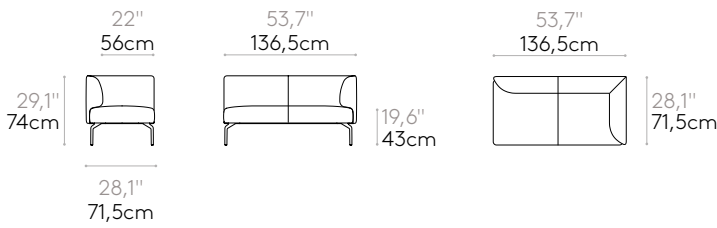

COM 140cm / 55,1" per unit	
1 unit	411,5cm / 162"
8 or more units	406cm / 159,8"
COM will be priced as G2	

37,1kg

1 unit
45,6 kg
0,75 m³
0,98 yd³



Recycled*



Recyclable*

Two seater module with end arm backrest (right)

Code: **KER0242**



Upholstered 2 seater module with right end arm. Inner seat made of plywood padded with CMHR polyurethane foam of various densities covered with soft polyester fiber. Backrest with inner frame in steel padded with CMHR polyurethane foam of 50kg/m³ covered with soft polyester fiber. Optionally the module can incorporate an upholstered privacy screen made of plywood and polyester fibre.

Upholstery: in all the fabrics and leathers indicated in our finishes book.

Legs: cast aluminum legs painted in all the M1 and M2 colours of our metal swatch card. Optionally available with polished finish.

Glides: plastic glides as standard. Felt glides are available with an upcharge.

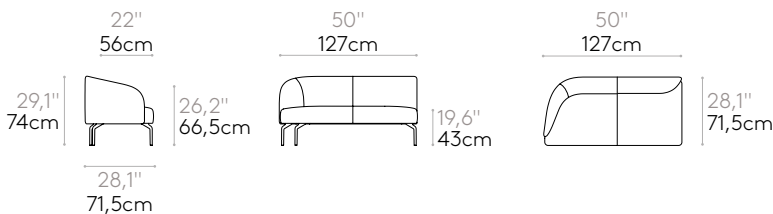

COM 140cm / 55,1" per unit	
1 unit	395cm / 155,5"
8 or more units	390,5cm / 153,7"
COM will be priced as G2	

29,7kg

1 unit
38,2 kg
0,80 m³
1,05 yd³



Recycled*



Recyclable*

* Numbers may vary based on the exact options selected.

Two seater module with end arm backrest (left)

Code: **KER0244**



Upholstered 2 seater module with left end arm. Inner seat made of plywood padded with CMHR polyurethane foam of various densities covered with soft polyester fiber. Backrest with inner frame in steel padded with CMHR polyurethane foam of 50kg/m³ covered with soft polyester fiber. Optionally the module can incorporate an upholstered privacy screen made of plywood and polyester fibre.

Upholstery: in all the fabrics and leathers indicated in our finishes book.

Legs: cast aluminum legs painted in all the M1 and M2 colours of our metal swatch card. Optionally available with polished finish.

Glides: plastic glides as standard. Felt glides are available with an upcharge.

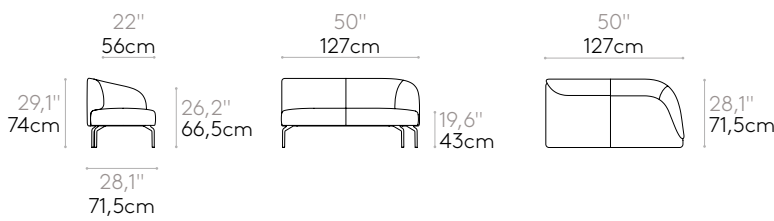

COM 140cm / 55,1" per unit	
1 unit	395cm / 155,5"
8 or more units	390,5cm / 153,7"
COM will be priced as G2	

KG	29,7kg	KD	1 unit	38,2 kg	0,80 m ³	1,05 yd ³
----	--------	----	--------	---------	---------------------	----------------------

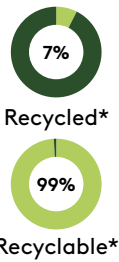

One seater concave/convex module 45°

Code: **KER0130**



Upholstered curved seat module. Inner seat made of plywood padded with CMHR polyurethane foam of various densities covered with soft polyester fiber.

Upholstery: in all the fabrics and leathers indicated in our finishes book.

Legs: cast aluminum legs painted in all the M1 and M2 colours of our metal swatch card. Optionally available with polished finish.

Glides: plastic glides as standard. Felt glides are available with an upcharge.

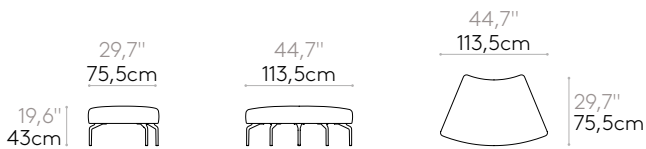

COM 140cm / 55,1" per unit	
1 unit	201,5cm / 79,3"
8 or more units	126,5cm / 49,8"
COM will be priced as G2	

KG	14,5kg	KD	2 units	38,2 kg	0,63 m ³	0,82 yd ³
----	--------	----	---------	---------	---------------------	----------------------

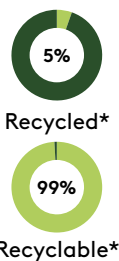

* Numbers may vary based on the exact options selected.

One seater concave module 45° with backrest

Code: **KER0230**



Upholstered concave curved seat module with backrest. Inner seat made of plywood padded with CMHR polyurethane foam of various densities covered with soft polyester fiber. Backrest with inner frame in steel padded with CMHR polyurethane foam of 50kg/m³ covered with soft polyester fiber. Optionally the module can incorporate an upholstered privacy screen made of plywood and polyester fibre.

Upholstery: in all the fabrics and leathers indicated in our finishes book.

Legs: cast aluminum legs painted in all the M1 and M2 colours of our metal swatch card. Optionally available with polished finish.

Glides: plastic glides as standard. Felt glides are available with an upcharge.

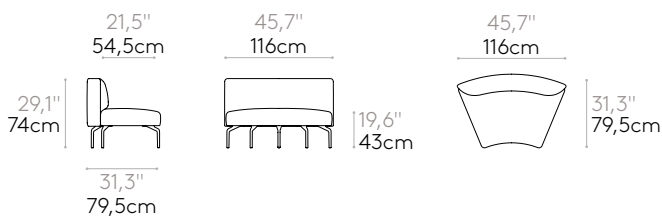

COM 140cm / 55,1" per unit	
1 unit	273cm / 107,5"
8 or more units	257,5cm / 101,4"
COM will be priced as G2	

25,3kg	1 unit	33,8 kg 0,64 m ³ 0,84 yd ³
--------	--------	--

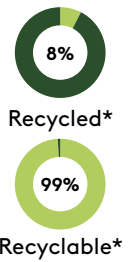

One seater convex module 45° with backrest

Code: **KER0232**



Upholstered convex curved seat module with backrest. Inner seat made of plywood padded with CMHR polyurethane foam of various densities covered with soft polyester fiber. Backrest with inner frame in steel padded with CMHR polyurethane foam of 50kg/m³ covered with soft polyester fiber. Optionally the module can incorporate an upholstered privacy screen made of plywood and polyester fibre.

Upholstery: in all the fabrics and leathers indicated in our finishes book.

Legs: cast aluminum legs painted in all the M1 and M2 colours of our metal swatch card. Optionally available with polished finish.

Glides: plastic glides as standard. Felt glides are available with an upcharge.

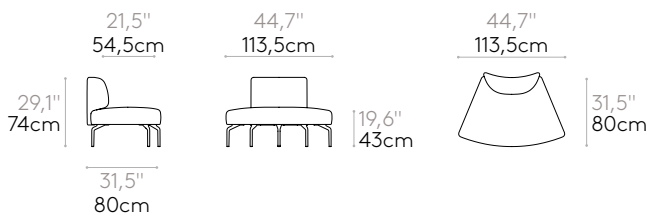

COM 140cm / 55,1" per unit	
1 unit	219cm / 86,2"
8 or more units	198cm / 78"
COM will be priced as G2	

20,8kg	1 unit	29,3 kg 0,63 m ³ 0,82 yd ³
--------	--------	--

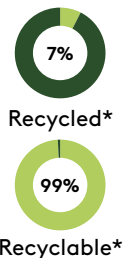

* Numbers may vary based on the exact options selected.

Round ottoman Ø70cm

Code: **KER0310**



Upholstered ottoman Ø70cm. Inner seat made of plywood padded with CMHR polyurethane foam of various densities covered with soft polyester fiber.

Upholstery: in all the fabrics and leathers indicated in our finishes book.

Legs: cast aluminum legs painted in all the M1 and M2 colours of our metal swatch card. Optionally available with polished finish.

Glides: plastic glides as standard. Felt glides are available with an upcharge.



COM 140cm / 55,1" per unit

1 unit	124,5cm / 49"
--------	---------------

8 or more units	89,5cm / 35,2"
-----------------	----------------

COM will be priced as G2

8,9kg

1 unit 11,6 kg
0,23 m³
0,30 yd³



Recycled*



Recyclable*

Round ottoman Ø100cm

Code: **KER0320**



Upholstered ottoman Ø100cm. Inner seat made of plywood padded with CMHR polyurethane foam of various densities covered with soft polyester fiber.

Upholstery: in all the fabrics and leathers indicated in our finishes book.

Legs: cast aluminum legs painted in all the M1 and M2 colours of our metal swatch card. Optionally available with polished finish.

Glides: plastic glides as standard. Felt glides are available with an upcharge.

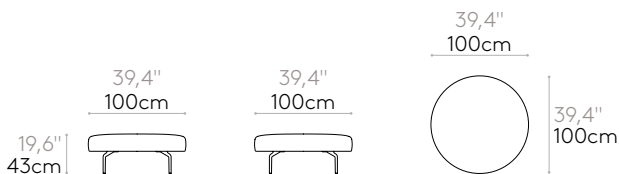

COM 140cm / 55,1" per unit

1 unit	222,5cm / 87,6"
--------	-----------------

8 or more units	154cm / 60,6"
-----------------	---------------

COM will be priced as G2

14,9kg

1 unit 19 kg
0,46 m³
0,60 yd³



Recycled*



Recyclable*

* Numbers may vary based on the exact options selected.

Round ottoman Ø120cm

Code: **KER0330**



Upholstered ottoman Ø120cm. Inner seat made of plywood padded with CMHR polyurethane foam of various densities covered with soft polyester fiber.

Upholstery: in all the fabrics and leathers indicated in our finishes book.

Legs: cast aluminum legs painted in all the M1 and M2 colours of our metal swatch card. Optionally available with polished finish.

Glides: plastic glides as standard. Felt glides are available with an upcharge.

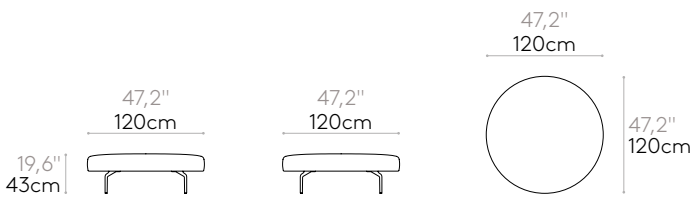

COM 140cm / 55,1" per unit

1 unit	267,5cm / 105,3"
--------	------------------

8 or more units	207cm / 81,5"
-----------------	---------------

COM will be priced as G2

20,7kg

1 unit 26,3 kg
0,57 m³
0,75 yd³



Recycled*



Recyclable*

Electrifiable table 70x70cm

Code: **KER0710**



Modular low table with wooden top and upholstered base 70x70cm. Sides covered with soft fiber. The interior of the table is hollow to allow the installation of the different electrification accessories.

Upholstery: in all the fabrics and leathers indicated in our finishes book.

Top finishes: in any of the oak veneer, walnut veneer, solid HPL white and sand core, solid HPL STONES, and solid FENIX® finishes or lacquered in colours W1 and W2 from our tabletops swatch card.

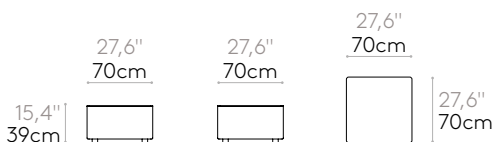

COM 140cm / 55,1" per unit

1 unit	147,5cm / 58,1"
--------	-----------------

8 or more units	147,5cm / 58,1"
-----------------	-----------------

COM will be priced as G2

19,9kg

1 unit 22,6 kg
0,23 m³
0,30 yd³



Recycled*



Recyclable*

* Numbers may vary based on the exact options selected.

Connecting side table 70x70 with height 26cm

Code: **KER0410**



Connecting side table 70x70cm with 4 legs for modular compositions.

Top finishes: in any of the oak veneer, walnut veneer, solid HPL white and sand core, solid HPL STONES, and solid FENIX® finishes or lacquered in colours W1 and W2 from our tabletops swatch card.

Legs: cast aluminum legs painted in all the M1 and M2 colours of our metal swatch card. Optionally available with polished finish.

Glides: plastic glides as standard. Felt glides are available with an upcharge.

Tabletop	Shipping data			Recycled*	Recyclable*	
Oak natural/stained	KG	8,7kg	1 unit KD	10 kg 0,06 m ³ 0,08 yd ³	66%	99%
Walnut natural	KG	8,7kg	1 unit KD	10 kg 0,06 m ³ 0,08 yd ³	66%	99%
Lacquered MDF colours W1	KG	8,5kg	1 unit KD	9,8 kg 0,06 m ³ 0,08 yd ³	72%	99%
Lacquered MDF colours W2	KG	8,5kg	1 unit KD	9,8 kg 0,06 m ³ 0,08 yd ³	72%	99%
Solid FENIX® 12mm* black core	KG	9,8kg	1 unit KD	11,1 kg 0,06 m ³ 0,08 yd ³	73%	99%
Solid HPL 12mm* white / white core sand / sand core	KG	9,5kg	1 unit KD	10,8 kg 0,06 m ³ 0,08 yd ³	72%	99%
Solid HPL STONES 12mm*	KG	9,5kg	1 unit KD	10,8 kg 0,06 m ³ 0,08 yd ³	72%	99%



* Numbers may vary based on the exact options selected.

Concave/convex connecting side table 45° with height 26cm

Code: **KER0420**



Connecting side table 45° (concave-convex) with 4 legs for modular compositions.

Top finishes: in any of the oak veneer, walnut veneer, solid HPL white and sand core, solid HPL STONES, and solid FENIX® finishes or lacquered in colours W1 and W2 from our tabletops swatch card.

Legs: cast aluminum legs painted in all the M1 and M2 colours of our metal swatch card. Optionally available with polished finish.

Glides: plastic glides as standard. Felt glides are available with an upcharge.

Tabletop	Shipping data			Recycled*	Recyclable*
Oak natural/stained	10,9kg	1 unit KD	13,4 kg 0,08 m ³ 0,11 yd ³		
Walnut natural	10,9kg	1 unit KD	13,4 kg 0,08 m ³ 0,11 yd ³		
Lacquered MDF colours W1	10,5kg	1 unit KD	13 kg 0,08 m ³ 0,11 yd ³		
Lacquered MDF colours W2	10,5kg	1 unit KD	13 kg 0,08 m ³ 0,11 yd ³		
Solid FENIX® 12mm* black core	12,2kg	1 unit KD	14,7 kg 0,08 m ³ 0,11 yd ³		
Solid HPL 12mm* white / white core sand / sand core	11,8kg	1 unit KD	14,3 kg 0,08 m ³ 0,11 yd ³		
Solid HPL STONES 12mm*	11,8kg	1 unit KD	14,3 kg 0,08 m ³ 0,11 yd ³		

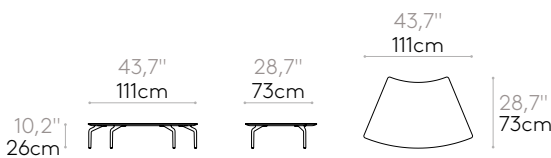

* Numbers may vary based on the exact options selected.

LOW TABLES

Square side table 70x70cm with height 35cm

Code: **KER0530**



Side table 70x70cm with 4 legs.

Top finishes: in any of the oak veneer, walnut veneer, solid HPL white and sand core, solid HPL STONES, and solid FENIX® finishes or lacquered in colours W1 and W2 from our tabletops swatch card.

Legs: cast aluminum legs painted in all the M1 and M2 colours of our metal swatch card. Optionally available with polished finish.

Glides: plastic glides as standard. Felt glides are available with an upcharge.

Tabletop	Shipping data			Recycled*	Recyclable*
Oak natural/stained	KG	8,8kg	1 unit KD 10,1 kg 0,06 m ³ 0,08 yd ³	66%	99%
Walnut natural	KG	8,8kg	1 unit KD 10,1 kg 0,06 m ³ 0,08 yd ³	66%	99%
Lacquered MDF colours W1	KG	8,6kg	1 unit KD 9,9 kg 0,06 m ³ 0,08 yd ³	71%	99%
Lacquered MDF colours W2	KG	8,6kg	1 unit KD 9,9 kg 0,06 m ³ 0,08 yd ³	71%	99%
Solid FENIX® 12mm* black core	KG	9,9kg	1 unit KD 11,2 kg 0,06 m ³ 0,08 yd ³	75%	99%
Solid HPL 12mm* white / white core sand / sand core	KG	9,6kg	1 unit KD 10,9 kg 0,06 m ³ 0,08 yd ³	74%	99%
Solid HPL STONES 12mm*	KG	9,6kg	1 unit KD 10,9 kg 0,06 m ³ 0,08 yd ³	74%	99%



* Numbers may vary based on the exact options selected.

Square coffee table 90x90cm with height 35cm

Code: **KER0540**



Coffee table 90x90cm with 4 legs.

Top finishes: in any of the oak veneer, walnut veneer, solid HPL white and sand core, solid HPL STONES, and solid FENIX® finishes or lacquered in colours W1 and W2 from our tabletops swatch card.

Legs: cast aluminum legs painted in all the M1 and M2 colours of our metal swatch card. Optionally available with polished finish.

Glides: plastic glides as standard. Felt glides are available with an upcharge.

Tabletop	Shipping data			Recycled*	Recyclable*
Oak natural/stained	14,3kg	1 unit KD	16 kg 0,08 m ³ 0,11 yd ³	75%	99%
Walnut natural	14,3kg	1 unit KD	16 kg 0,08 m ³ 0,11 yd ³	75%	99%
Lacquered MDF colours W1	13,8kg	1 unit KD	15,5 kg 0,08 m ³ 0,11 yd ³	82%	99%
Lacquered MDF colours W2	13,8kg	1 unit KD	15,5 kg 0,08 m ³ 0,11 yd ³	82%	99%
Solid FENIX® 12mm* black core	15,9kg	1 unit KD	17,6 kg 0,08 m ³ 0,11 yd ³	84%	99%
Solid HPL 12mm* white / white core sand / sand core	15,4kg	1 unit KD	17,1 kg 0,08 m ³ 0,11 yd ³	84%	99%
Solid HPL STONES 12mm*	15,4kg	1 unit KD	17,1 kg 0,08 m ³ 0,11 yd ³	84%	99%



* Numbers may vary based on the exact options selected.

Round side table Ø70cm with height 35cm

Code: **KER0510**



Round side table Ø70cm with 4 legs.

Top finishes: in any of the oak veneer, walnut veneer, solid HPL white and sand core, solid HPL STONES, and solid FENIX® finishes or lacquered in colours W1 and W2 from our tabletops swatch card.

Legs: cast aluminum legs painted in all the M1 and M2 colours of our metal swatch card. Optionally available with polished finish.

Glides: plastic glides as standard. Felt glides are available with an upcharge.

Tabletop	Shipping data			Recycled*	Recyclable*
Oak natural/stained	7,9kg	1 unit KD	9,2 kg 0,06 m ³ 0,08 yd ³		
Walnut natural	7,9kg	1 unit KD	9,2 kg 0,06 m ³ 0,08 yd ³		
Lacquered MDF colours W1	7,7kg	1 unit KD	9 kg 0,06 m ³ 0,08 yd ³		
Lacquered MDF colours W2	7,7kg	1 unit KD	9 kg 0,06 m ³ 0,08 yd ³		
Solid FENIX® 12mm* black core	8,8kg	1 unit KD	10,1 kg 0,06 m ³ 0,08 yd ³		
Solid HPL 12mm* white / white core sand / sand core	8,6kg	1 unit KD	9,9 kg 0,06 m ³ 0,08 yd ³		
Solid HPL STONES 12mm*	8,6kg	1 unit KD	9,9 kg 0,06 m ³ 0,08 yd ³		



* Numbers may vary based on the exact options selected.

Round coffee table Ø90cm with height 35cm

Code: **KER0520**



Round coffee table Ø90cm with 4 legs.

Top finishes: in any of the oak veneer, walnut veneer, solid HPL white and sand core, solid HPL STONES, and solid FENIX® finishes or lacquered in colours W1 and W2 from our tabletops swatch card.

Legs: cast aluminum legs painted in all the M1 and M2 colours of our metal swatch card. Optionally available with polished finish.

Glides: plastic glides as standard. Felt glides are available with an upcharge.

Tabletop	Shipping data			Recycled*	Recyclable*
Oak natural/stained	11,7kg	1 unit KD	13,4 kg 0,08 m ³ 0,11 yd ³		
Walnut natural	11,7kg	1 unit KD	13,4 kg 0,08 m ³ 0,11 yd ³		
Lacquered MDF colours W1	11,3kg	1 unit KD	13 kg 0,08 m ³ 0,11 yd ³		
Lacquered MDF colours W2	11,3kg	1 unit KD	13 kg 0,08 m ³ 0,11 yd ³		
Solid FENIX® 12mm* black core	13kg	1 unit KD	14,7 kg 0,08 m ³ 0,11 yd ³		
Solid HPL 12mm* white / white core sand / sand core	12,6kg	1 unit KD	14,3 kg 0,08 m ³ 0,11 yd ³		
Solid HPL STONES 12mm*	12,6kg	1 unit KD	14,3 kg 0,08 m ³ 0,11 yd ³		



* Numbers may vary based on the exact options selected.

Rectangular coffee table 110x60cm with height 35cm

Code: **KER0550**



Rectangular coffee table 110x60cm with 4 legs.

Top finishes: in any of the oak veneer, walnut veneer, solid HPL white and sand core, solid HPL STONES, and solid FENIX® finishes or lacquered in colours W1 and W2 from our tabletops swatch card.

Legs: cast aluminum legs painted in all the M1 and M2 colours of our metal swatch card. Optionally available with polished finish.

Glides: plastic glides as standard. Felt glides are available with an upcharge.

Tabletop	Shipping data			Recycled*	Recyclable*
Oak natural/stained	12kg	1 unit KD	14,5 kg 0,07 m ³ 0,10 yd ³		
Walnut natural	12kg	1 unit KD	14,5 kg 0,07 m ³ 0,10 yd ³		
Lacquered MDF colours W1	11,6kg	1 unit KD	14,1 kg 0,07 m ³ 0,10 yd ³		
Lacquered MDF colours W2	11,6kg	1 unit KD	14,1 kg 0,07 m ³ 0,10 yd ³		
Solid FENIX® 12mm* black core	13,4kg	1 unit KD	15,9 kg 0,07 m ³ 0,10 yd ³		
Solid HPL 12mm* white / white core sand / sand core	13kg	1 unit KD	15,5 kg 0,07 m ³ 0,10 yd ³		
Solid HPL STONES 12mm*	13kg	1 unit KD	15,5 kg 0,07 m ³ 0,10 yd ³		

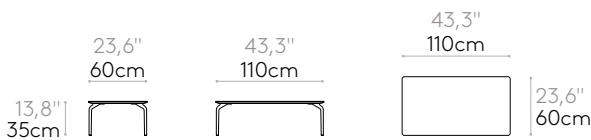

* Numbers may vary based on the exact options selected.

Oval coffee table 110x60cm with height 35cm

Code: **KER0560**



Oval coffee table 110x60cm with 4 legs.

Top finishes: in any of the oak veneer, walnut veneer, solid HPL white and sand core, solid HPL STONES, and solid FENIX® finishes or lacquered in colours W1 and W2 from our tabletops swatch card.

Legs: cast aluminum legs painted in all the M1 and M2 colours of our metal swatch card. Optionally available with polished finish.

Glides: plastic glides as standard. Felt glides are available with an upcharge.

Tabletop	Shipping data			Recycled*	Recyclable*
Oak natural/stained	11kg	1 unit KD	13,5 kg 0,07 m ³ 0,10 yd ³		
Walnut natural	11kg	1 unit KD	13,5 kg 0,07 m ³ 0,10 yd ³		
Lacquered MDF colours W1	10,6kg	1 unit KD	13,1 kg 0,07 m ³ 0,10 yd ³		
Lacquered MDF colours W2	10,6kg	1 unit KD	13,1 kg 0,07 m ³ 0,10 yd ³		
Solid FENIX® 12mm* black core	12,2kg	1 unit KD	14,7 kg 0,07 m ³ 0,10 yd ³		
Solid HPL 12mm* white / white core sand / sand core	11,9kg	1 unit KD	14,1 kg 0,07 m ³ 0,10 yd ³		
Solid HPL STONES 12mm*	11,9kg	1 unit KD	14,1 kg 0,07 m ³ 0,10 yd ³		



* Numbers may vary based on the exact options selected.

ROOMS *(SUGGESTED CONFIGURATIONS)

Room 4 positions L.160cm W.260cm (Configuration 1)

Code: **KER3010**



Configuration of 2 x Two seater sofa with panel (KER0030 + KER1030PC) + Privacy screen connection panel for room L.120cm (KER2120).

Inner seats made of plywood padded with CMHR polyurethane foam of various densities covered with soft polyester fiber. Backrest with inner frame in steel padded with CMHR polyurethane foam of 50 kg/m³ covered with soft polyester fiber. Privacy screens made with plywood and polyester fibre.

Upholstery: the sofas can be upholstered in all the fabrics and leathers indicated in our finishes book. The screens can be upholstered in fabrics from G1 to G7.

Legs: cast aluminum legs painted in all the M1 and M2 colours of our metal swatch card. Optionally available with polished finish.

Glides: plastic glides as standard. Felt glides are available with an upcharge.

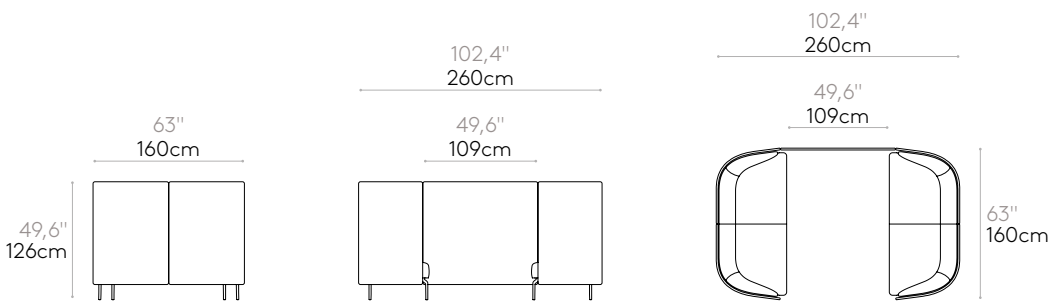

Room 4 positions L.160cm W.210cm (Configuration 2)

Code: **KER3020**



Configuration of 2x Two seater sofa with panel (KER0030 + KER1030PC) + Privacy screen connection panel for room L.70cm (KER2070).

Inner seats made of plywood padded with CMHR polyurethane foam of various densities covered with soft polyester fiber. Backrest with inner frame in steel padded with CMHR polyurethane foam of 50 kg/m³ covered with soft polyester fiber. Privacy screens made with plywood and polyester fibre.

Upholstery: the sofas can be upholstered in all the fabrics and leathers indicated in our finishes book. The screens can be upholstered in fabrics from G1 to G7.

Legs: cast aluminum legs painted in all the M1 and M2 colours of our metal swatch card. Optionally available with polished finish.

Glides: plastic glides as standard. Felt glides are available with an upcharge.

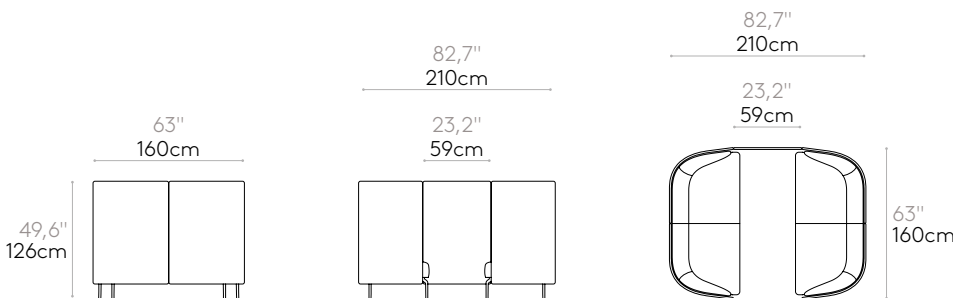

* Other configurations can be made upon request.

Room 6 positions L.228cm W.260cm (Configuration 3)

Code: **KER3030**



Configuration of 2x three seater sofa with panel (KER0040 + KER1040PC) + Privacy screen connection panel for room L.120cm (KER2120).

Inner seats made of plywood padded with CMHR polyurethane foam of various densities covered with soft polyester fiber. Backrest with inner frame in steel padded with CMHR polyurethane foam of 50 kg/m³ covered with soft polyester fiber. Privacy screens made with plywood and polyester fibre.

Upholstery: the sofas can be upholstered in all the fabrics and leathers indicated in our finishes book. The screens can be upholstered in fabrics from G1 to G7.

Legs: cast aluminum legs painted in all the M1 and M2 colours of our metal swatch card. Optionally available with polished finish.

Glides: plastic glides as standard. Felt glides are available with an upcharge.

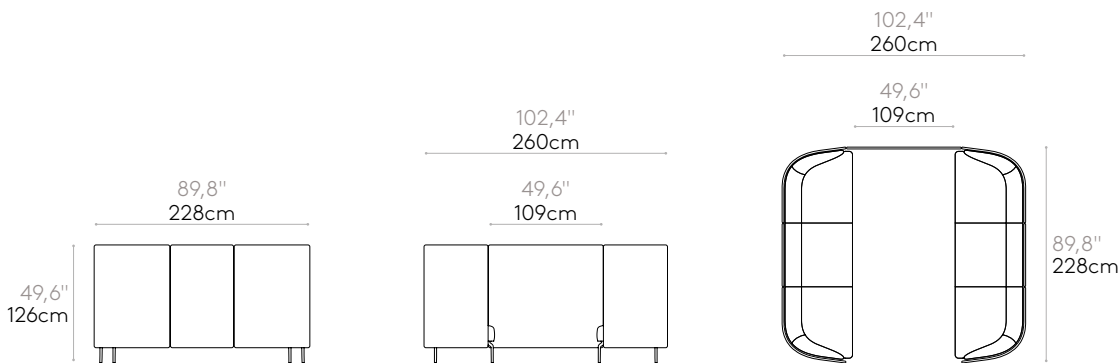

Room 6 positions L.228cm W.210cm (Configuration 4)

Code: **KER3040**



Configuration of 2x three seater sofa with panel (KER0040 + KER1040PC) + Privacy screen connection panel for room L.70cm (KER2070).

Inner seats made of plywood padded with CMHR polyurethane foam of various densities covered with soft polyester fiber. Backrest with inner frame in steel padded with CMHR polyurethane foam of 50 kg/m³ covered with soft polyester fiber. Privacy screens made with plywood and polyester fibre.

Upholstery: the sofas can be upholstered in all the fabrics and leathers indicated in our finishes book. The screens can be upholstered in fabrics from G1 to G7.

Legs: cast aluminum legs painted in all the M1 and M2 colours of our metal swatch card. Optionally available with polished finish.

Glides: plastic glides as standard. Felt glides are available with an upcharge.

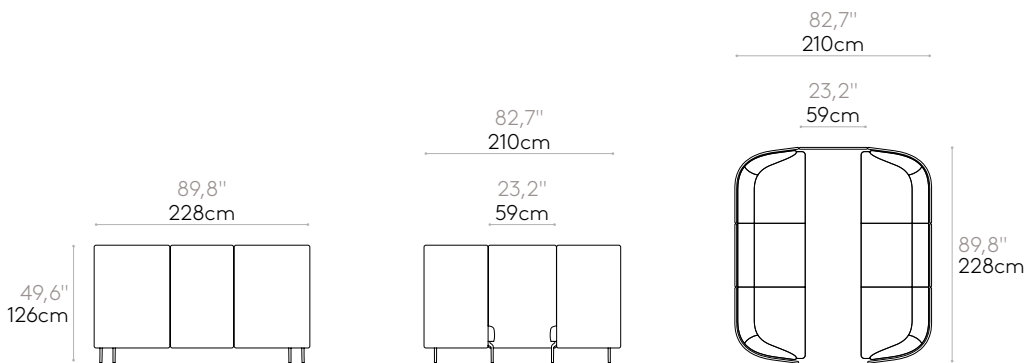

* Other configurations can be made upon request.

Room 4 positions L.148cm W.260cm (Configuration 5)

Code: **KER3050**



Configuration of two seater module with end arm backrest (right) with panel (KER0242 + KER1242PC) + Two seater module with end arm backrest (left) with panel (KER0244 + KER1244PC) + Privacy screen connection panel for room L.120cm (KER2120).

Inner seats made of plywood padded with CMHR polyurethane foam of various densities covered with soft polyester fiber. Backrest with inner frame in steel padded with CMHR polyurethane foam of 50 kg/m³ covered with soft polyester fiber. Privacy screens made with plywood and polyester fibre.

Upholstery: the sofas can be upholstered in all the fabrics and leathers indicated in our finishes book. The screens can be upholstered in fabrics from G1 to G7.

Legs: cast aluminum legs painted in all the M1 and M2 colours of our metal swatch card. Optionally available with polished finish.

Glides: plastic glides as standard. Felt glides are available with an upcharge.

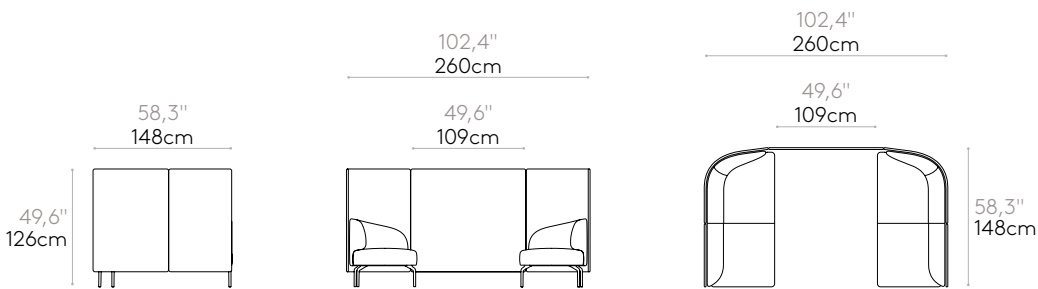

Room 4 positions L.148cm W.210cm (Configuration 6)

Code: **KER3060**



Configuration of two seater module with end arm backrest (right) with panel (KER0242 + KER1242PC) + Two seater module with end arm backrest (left) with panel (KER0244 + KER1244PC) + Privacy screen connection panel for room L.70cm (KER2070).

Inner seats made of plywood padded with CMHR polyurethane foam of various densities covered with soft polyester fiber. Backrest with inner frame in steel padded with CMHR polyurethane foam of 50 kg/m³ covered with soft polyester fiber. Privacy screens made with plywood and polyester fibre.

Upholstery: the sofas can be upholstered in all the fabrics and leathers indicated in our finishes book. The screens can be upholstered in fabrics from G1 to G7.

Legs: cast aluminum legs painted in all the M1 and M2 colours of our metal swatch card. Optionally available with polished finish.

Glides: plastic glides as standard. Felt glides are available with an upcharge.

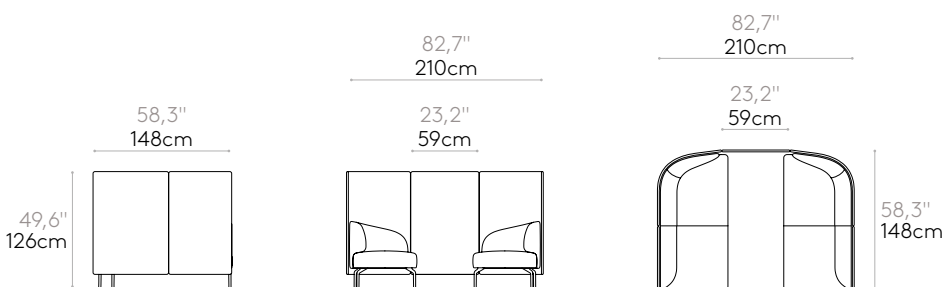

* Other configurations can be made upon request.

Room 4 positions L.142cm W.272cm (Configuration 7)

Code: **KER3070**



Configuration of two seater module with corner backrest (right) with panel (KER0222 + KER1222PC) + Two seater module with corner backrest (left) with panel (KER0224 + KER1224PC) + Privacy screen connection panel for room L.120cm (KER2120).

Inner seats made of plywood padded with CMHR polyurethane foam of various densities covered with soft polyester fiber. Backrest with inner frame in steel padded with CMHR polyurethane foam of 50 kg/m³ covered with soft polyester fiber. Privacy screens made with plywood and polyester fibre.

Upholstery: the sofas can be upholstered in all the fabrics and leathers indicated in our finishes book. The screens can be upholstered in fabrics from G1 to G7.

Legs: cast aluminum legs painted in all the M1 and M2 colours of our metal swatch card. Optionally available with polished finish.

Glides: plastic glides as standard. Felt glides are available with an upcharge.

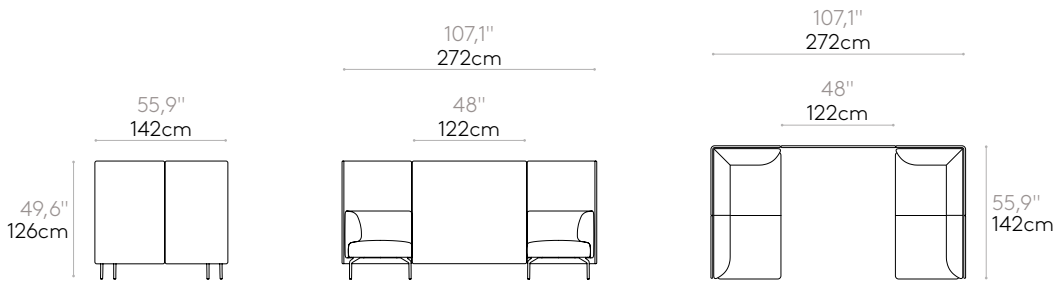

Room 4 positions L.142cm W.222cm (Configuration 8)

Code: **KER3080**



Configuration of two seater module with corner backrest (right) with panel (KER0222 + KER1222PC) + Two seater module with corner backrest (left) with panel (KER0224 + KER1224PC) + Privacy screen connection panel for room L.70cm (KER2070).

Inner seats made of plywood padded with CMHR polyurethane foam of various densities covered with soft polyester fiber. Backrest with inner frame in steel padded with CMHR polyurethane foam of 50 kg/m³ covered with soft polyester fiber. Privacy screens made with plywood and polyester fibre.

Upholstery: the sofas can be upholstered in all the fabrics and leathers indicated in our finishes book. The screens can be upholstered in fabrics from G1 to G7.

Legs: cast aluminum legs painted in all the M1 and M2 colours of our metal swatch card. Optionally available with polished finish.

Glides: plastic glides as standard. Felt glides are available with an upcharge.

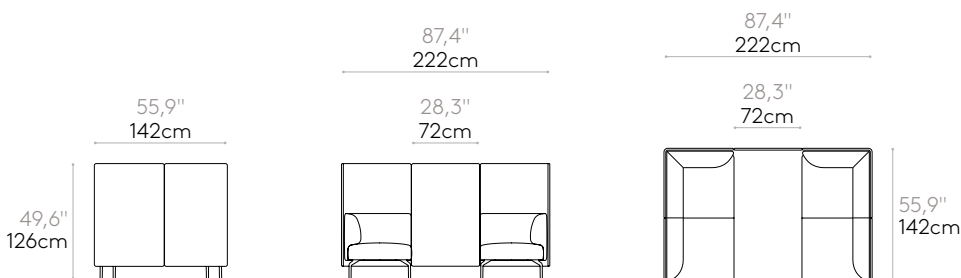

* Other configurations can be made upon request.

Meeting table L.130cm for 4 position room

Code: **KER0610**



Meeting table for four seater rooms with height 65cm.

Suitable for configurations: 1, 2, 5, 6, 7 and 8.

Top finishes: in any of the oak veneer, walnut veneer, solid HPL white and sand core, solid HPL STONES, and solid FENIX® finishes or lacquered in colours W1 and W2 from our tabletops swatch card.

Frame finishes: made of steel. Micro-textured powder coated in colours M1 and M2 from our metallic swatch card.

Tabletop	Datos de envío			Recycled*	Reciclable*
Oak natural/stained	24,3kg	1 unit KD	34,4 kg 0,84 m ³ 1,10 yd ³	81%	98%
Walnut natural	24,3kg	1 unit KD	34,4 kg 0,84 m ³ 1,10 yd ³	81%	98%
Lacquered MDF colours W1	23,8kg	1 unit KD	33,9 kg 0,84 m ³ 1,10 yd ³	85%	98%
Lacquered MDF colours W2	23,8kg	1 unit KD	33,9 kg 0,84 m ³ 1,10 yd ³	85%	98%
Solid FENIX® 12mm* black core	25,7kg	1 unit KD	35,8 kg 0,84 m ³ 1,10 yd ³	86%	98%
Solid HPL 12mm* white / white core sand / sand core	25,2kg	1 unit KD	35,3 kg 0,84 m ³ 1,10 yd ³	85%	98%
Solid HPL STONES 12mm*	25,2kg	1 unit KD	35,3 kg 0,84 m ³ 1,10 yd ³	85%	98%

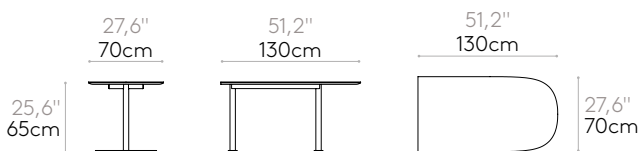

* Numbers may vary based on the exact options selected.

Meeting table L.200cm for 6 position room

Code: **KER0620**



Meeting table for six seater rooms with height 65cm.

Suitable for configurations: 3 and 4.

Top finishes: in any of the oak veneer, walnut veneer, solid HPL white and sand core, solid HPL STONES, and solid FENIX® finishes or lacquered in colours W1 and W2 from our tabletops swatch card.

Frame finishes: made of steel. Micro-textured powder coated in colours M1 and M2 from our metallic swatch card.

Tabletop	Datos de envío			Recycled*	Reciclable*
Oak natural/stained	33,8kg	1 unit KD	47,3 kg 1,24 m ³ 1,62 yd ³		
Walnut natural	33,8kg	1 unit KD	47,3 kg 1,24 m ³ 1,62 yd ³		
Lacquered MDF colours W1	33kg	1 unit KD	46,5 kg 1,24 m ³ 1,62 yd ³		
Lacquered MDF colours W2	33kg	1 unit KD	46,5 kg 1,24 m ³ 1,62 yd ³		
Solid FENIX® 12mm* black core	36,4kg	1 unit KD	50 kg 1,24 m ³ 1,62 yd ³		
Solid HPL 12mm* white / white core sand / sand core	35,6kg	1 unit KD	49,1 kg 1,24 m ³ 1,62 yd ³		
Solid HPL STONES 12mm*	35,6kg	1 unit KD	49,1 kg 1,24 m ³ 1,62 yd ³		



* Numbers may vary based on the exact options selected.

Privacy screen for armchairs & sofas



Upholstered privacy screen on 3 sides for armchairs and sofas. Inner made of plywood covered with soft polyester fibre.

Remark: if you require this sofa to make a room, please clearly indicate it in your PO.

Upholstery: in all the fabrics G1 to G7 of our finishes book.

Privacy screen for armchair

Code: **KER1020PC**

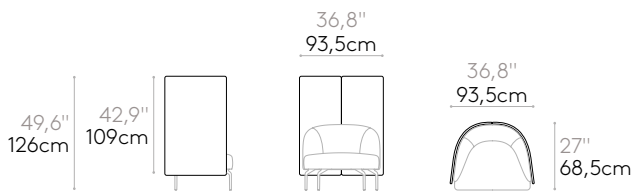

COM 140cm / 55,1" per unit

1 unit	416cm / 163,8"
8 or more units	416cm / 163,8"

COM will be priced as G2

KG	20,6kg	1 unit	22,6 kg
		KD	0,28 m ³
			0,36 yd ³



Recycled*



Recyclable*

Privacy screen for two seater sofa

Code: **KER1030PC**

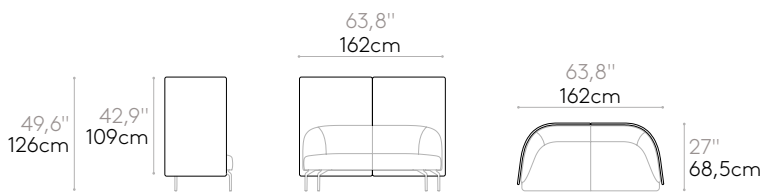

COM 140cm / 55,1" per unit

1 unit	572cm / 225,5"
8 or more units	572cm / 225,5"

COM will be priced as G2

KG	28,4kg	1 unit	30,4 kg
		KD	0 m ³
			0 yd ³



Recycled*



Recyclable*

Privacy screen for three seater sofa

Code: **KER1040PC**

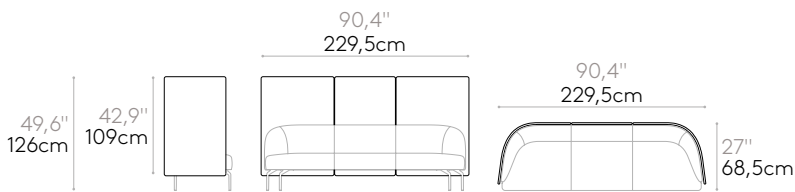

COM 140cm / 55,1" per unit

1 unit	730,5cm / 287,6"
8 or more units	730,5cm / 287,6"

COM will be priced as G2

KG	36,7kg	1 unit	38,7 kg
		KD	0 m ³
			0 yd ³



Recycled*



Recyclable*

* Numbers may vary based on the exact options selected.

Privacy screen for modular seats



Upholstered privacy screen modules with backrest. Inner made of plywood covered with soft polyester fibre.

Remark: for compositions with screens to be linked to each other, please send a drawing.

Upholstery: in all the fabrics G1 to G7 of our finishes book.

Privacy screen for one seater module with backrest

Code: **KER1210PT**

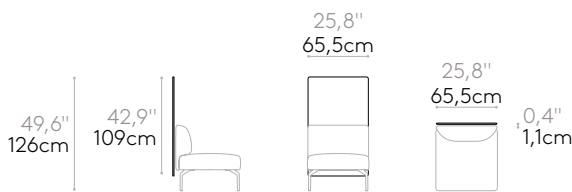

COM 140cm / 55,1" per unit	
1 unit	158,5cm / 62,4"
8 or more units	158,5cm / 62,4"
COM will be priced as G2	

8,3kg	1 unit	10,3 kg 0 m ³ 0 yd ³
-------	--------	--

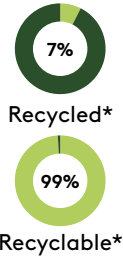

Privacy screen for one seater module with corner backrest

Code: **KER1212PC**

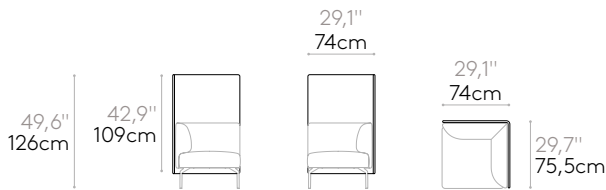

COM 140cm / 55,1" per unit	
1 unit	334,5cm / 131,7"
8 or more units	334,5cm / 131,7"
COM will be priced as G2	

17,3kg	1 unit	19,3 kg 0 m ³ 0 yd ³
--------	--------	--

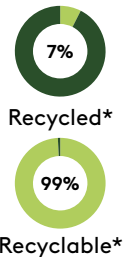

Privacy screen for two seater module with backrest

Code: **KER1220PT**

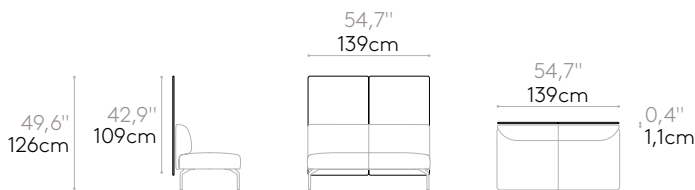

COM 140cm / 55,1" per unit	
1 unit	317cm / 124,8"
8 or more units	317cm / 124,8"
COM will be priced as G2	

16,7kg	1 unit	18,7 kg 0 m ³ 0 yd ³
--------	--------	--

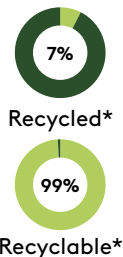

Privacy screen for two seater module with corner backrest (right)

Code: **KER1222PC**

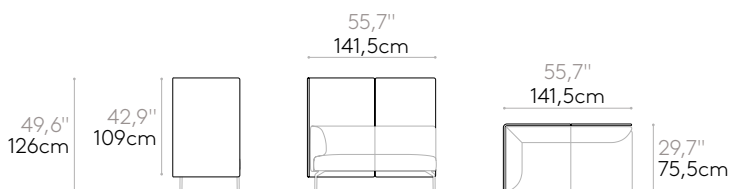

COM 140cm / 55,1" per unit	
1 unit	493cm / 194,1"
8 or more units	493cm / 194,1"
COM will be priced as G2	

25,6kg	1 unit	27,6 kg 0 m ³ 0 yd ³
--------	--------	--

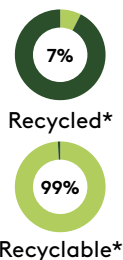

* Numbers may vary based on the exact options selected.

Privacy screen for two seater module with corner backrest (left)

Code: KER1224PC

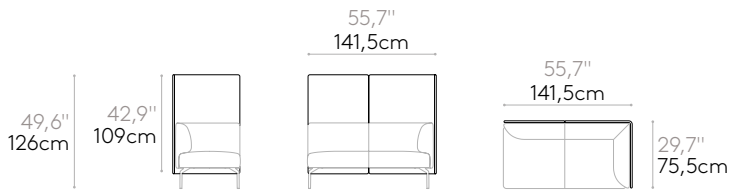

COM 140cm / 55,1" per unit

1 unit	493cm / 194,1"
8 or more units	493cm / 194,1"

COM will be priced as G2

KG 25,6kg

KD 1 unit
27,6 kg
0 m³
0 yd³



Recycled*



Recyclable*

Privacy screen for one seater concave module 45° with backrest

Code: KER1230PT

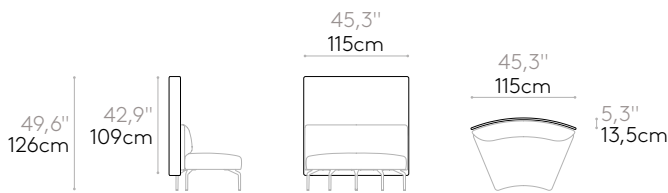

COM 140cm / 55,1" per unit

1 unit	251cm / 98,8"
8 or more units	251cm / 98,8"

COM will be priced as G2

KG 12,9kg

KD 1 unit
14,9 kg
0 m³
0 yd³



Recycled*



Recyclable*

Privacy screen for one seater convex module 45° with backrest

Code: KER1250PT

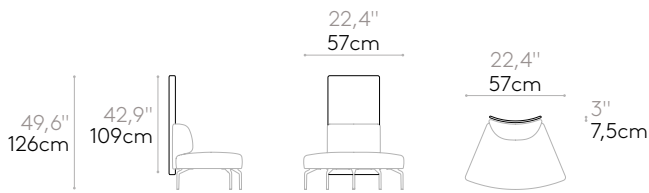

COM 140cm / 55,1" per unit

1 unit	125,5cm / 49,4"
8 or more units	125,5cm / 49,4"

COM will be priced as G2

KG 7,1kg

KD 1 unit
9,1 kg
0 m³
0 yd³



Recycled*



Recyclable*

Privacy screen for two seater module with end arm backrest (right)

Code: KER1242PC

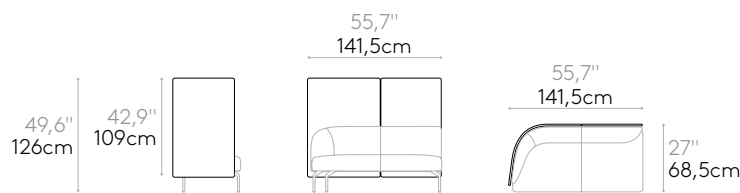

COM 140cm / 55,1" per unit

1 unit	444,5cm / 175"
8 or more units	444,5cm / 175"

COM will be priced as G2

KG 22,5kg

KD 1 unit
24,5 kg
0 m³
0 yd³



Recycled*



Recyclable*

Privacy screen for two seater module with end arm backrest (left)

Code: KER1244PC

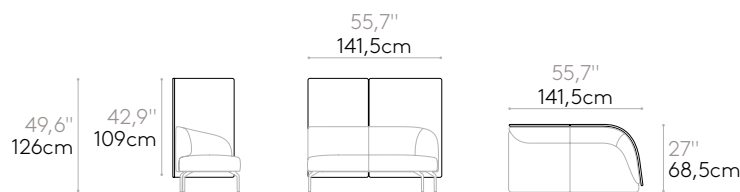

COM 140cm / 55,1" per unit

1 unit	444,5cm / 175"
8 or more units	444,5cm / 175"

COM will be priced as G2

KG 22,5kg

KD 1 unit
24,5 kg
0 m³
0 yd³



Recycled*



Recyclable*

* Numbers may vary based on the exact options selected.

Privacy screen connection for rooms



Upholstered connecting privacy screen for rooms. Inner made of plywood covered with soft polyester fibre.

Remark: for compositions with these screens, please send a drawing of the composition you require.

Upholstery: in all the fabrics G1 to G7 of our finishes book.

Privacy screen for room L.70cm

Code: **KER2070**

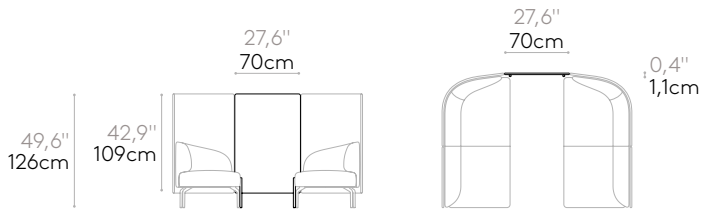

COM 140cm / 55,1" per unit

1 unit	170,5cm / 67,1"
8 or more units	170,5cm / 67,1"

COM will be priced as G2

9,3kg

1 unit
11,3 kg
0 m³
0 yd³



Recycled*



Recyclable*

Privacy screen for room L.120cm

Code: **KER2120**



COM 140cm / 55,1" per unit

1 unit	282cm / 111"
8 or more units	282cm / 111"

COM will be priced as G2

17,3kg

1 unit
19,3 kg
0 m³
0 yd³





Recycled*



Recyclable*

* Numbers may vary based on the exact options selected.

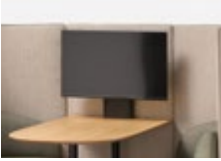
OPTIONAL ITEMS & ACCESSORIES

Code	Description
 KER0890	Totem for TV monitor (upcharge)
KER0820OP	Set of 4 felt glides (upcharge)
KER0830OP	Set of 5 felt glides for 45° curved modules (upcharge)
 KER0860OP	Set of 4 felt glides for aluminum swivel base (upcharge)
KER0840	Set of 4 legs with casters (upcharge)
KER0850	Set of legs with 5 casters for 45° curved modules (upcharge)
 KER0810UN	Linking bracket for modules (set of 2)

OPTIONAL ITEMS & ACCESSORIES

	Code	Description
	ELC0010	<p>Plastic cable grommet with cover Ø80mm (Available in black or white)</p> <p>*A drawing of the top with the exact position of cut-outs must be attached to the order.</p>
	ELC0020EL	<p>Brushed aluminum grommet with cover Ø80mm</p> <p>*A drawing of the top with the exact position of cut-outs must be attached to the order.</p>
	ELC0030EL	<p>Wireless induction charger Ø80mm (Output: 2m cable USB-A)</p> <p>*A drawing of the top with the exact position of cut-outs must be attached to the order.</p>
	ELC0040EL	<p>USB charger with 2 ports Ø30mm (Output: 1,5m cable + Schucko transformer)</p> <p>*A drawing of the top with the exact position of cut-outs must be attached to the order.</p>
	ELC0050EL	<p>On top Schuko socket Ø56mm (Output: 20cm cable + WIELAND connection)</p> <p>*A drawing of the top with the exact position of cut-outs must be attached to the order</p>
	ELC0090EL	<p>On top Schuko socket + USB-A + USB-C Ø60mm (Output: 20cm cable + WIELAND connection)</p> <p>*A drawing of the top with the exact position of cut-outs must be attached to the order</p>
	KER0870OP	<p>Power box with 2 Schuko plugs Output: 26cm cable + WIELAND connection)</p>